

VM-1 Application Board 3 (Issue B) Data Sheet

Introduction

The 5811 is an application board for use with the VM-1 Controller. The application board is designed primarily to provide connections for modules such as the 5809 QVGA display interface and 5810 ethernet controller. To support the QVGA the board has connectors for both display and touch screen. In addition the board provides an RS232 serial port, an optional second RS232 serial port, I²C connectors on Buses 1 and 2, an on-board EEPROM for non-volatile data storage and connectors for an alpha LCD and keypad. Additionally all the digital and analogue channels on the VM-1 connector are available¹.

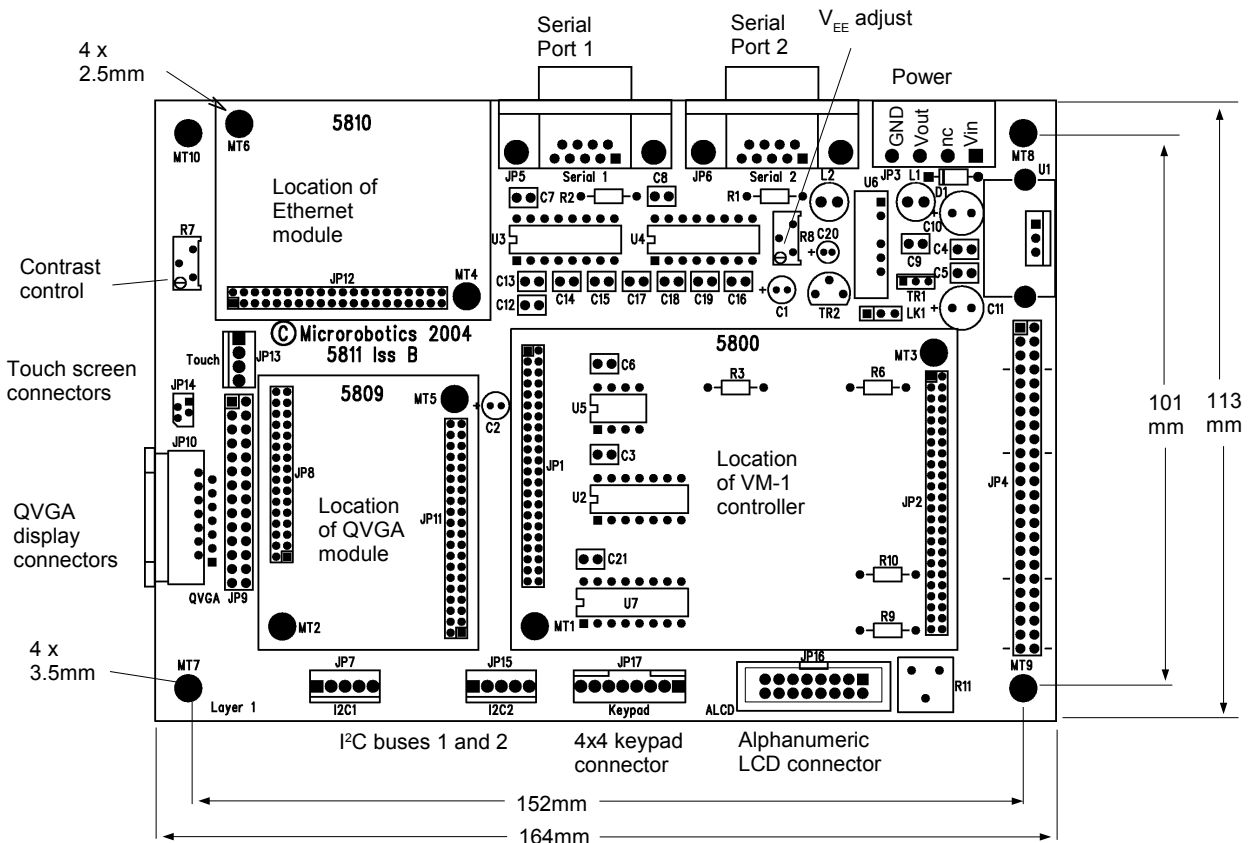

Unpacking

You should have:

- 5811 Application Board. This document applies to Issue B of the board and later.
- Power Connector

¹ Some channels are used to control functions on the board, as well as being available for general use.

WARNING: Users of Micro-Robotics Control Equipment should be aware of the possibility of a system failure, and must consider the implications of such failure. Micro-Robotics Ltd. can accept no responsibility for loss, injury, or damage resulting from the failure of our equipment. Use of our products in applications where their failure to perform as specified could result in injury or death is expressly forbidden.

- These Instructions

What You Will Need

To start using the application board you will need:

- VM-1 Control Module (5800 or 5801) with language ROM (5803)
- 8 to 30V 300mA unregulated DC power supply
- An RS232 serial lead to connect the 5811 to your host computer. Use a lead that would be used to connect two PCs together (a "Null Modem" cable)
- A PC running terminal emulation software such as Hyperterminal or Tera Term Pro.
- The VM-1 and Venom-SC manual set
- Optionally a QVGA card (5809) or ethernet card (5810)

Serial Ports

The RS232 level shifter ICs are socketed. Leave them in if you wish to use standard RS232 voltage levels (normal with serial cables such as links to a PC). If you need to use the logic-level signals (typically for internal connection to small PCB modules and ICs), remove the RS-232 IC and use the serial channels on JP4.

Serial Port 1 RS232

Pinout

Connector: JP5

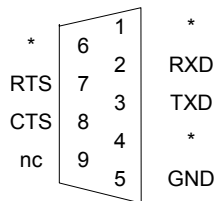

* Pins 1, 4 and 6 are connected to each other on the 5811

Configuration

Serial Port 1 is already configured for you in the default startup procedure with the line:

```
MAKE serial AsynchronousSerial(38400, 1, 1)
```

Serial Port 2 RS232

Pinout

Connector: JP6

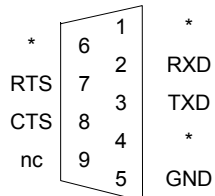

* Pins 1, 4 and 6 are connected to each other on the 5811

Configuration

Serial port 2 is not created by default. You can create it with a line like this:

```
MAKE serial AsynchronousSerial(38400, 2, 1)
```

Module Connections

The connections for the QVGA and ethernet boards are very similar, but for practical convenience and simplicity one socket is dedicated to each type. It is possible to use both modules at once.

The common module interface is described first.

Module Bus Connectors JP11, JP12

The following table describes the general module interface pinout.

Pin	Signal	Description
1	VCC	+5V supply
2	GND	Ground
3	D1	Data bus
4	D0	
5	D3	
6	D2	
7	D5	
8	D4	
9	D7	
10	D6	
11	VCC	+5V supply
12	GND	Ground
13	A1	Address bus
14	A0	
15	A3	
16	A2	
17	A5	
18	A4	
19	A7	
20	A6	
21	A9	
22	A8	
23	VCC	+5V supply
24	GND	Ground
25	A11	Address bus
26	A10	
27	A13	
28	A12	
29	A15	
30	A14	
31	HWR/	Write strobe
32	A16	Address bus
33	WAIT/	Delays write cycle
34	RD/	Read Strobe
35	RESET/	System Reset
36	SELECT/	See below
37	SDA	I ² C data
38	SCL	I ² C clock
39	VCC	+5V supply
40	GND	Ground

Implementation on Application Board 3

SDA and SCL are from the VM-1's I²C Bus 1.

SELECT/ is the 'device select' strobe for the module.

In the Venom language, The MAKE statements for the QVGA display, touch screen and ethernet interface have parameters which select the I²C bus and the correct module's SELECT/ signal, described later.

Ethernet Module

Connection

If an ethernet module 5811 is required, plug it into the ethernet module socket and secure it with a 6mm spacer, M2.5 screw and nut using hole MT6. A second spacer and mounting screw in MT4 is optional.

Use a length of CAT5 UTP cable to connect the ethernet board to a hub or switch that will support 10Mbit operation. Exceptionally, when the VM-1 is one end of a two-node network you can link the nodes directly with a UTP "crossover" cable.

Configuration

```
MAKE eth Protocol("eth", 1, $d, my_ip_address)
```

The second and third parameter specify I²C bus 1 and the correct addressing information to select the ethernet position on the 5811 application board.

See the Venom Networking Guide for more information, including the use of the `my_ip_address` parameter.

QVGA Module

N.B. Before powering up with a display connected, first adjust the supply voltage (see page 6)

If a QVGA module 5810 is required, plug it into the QVGA module sockets. Securing via mounting holes is optional as the board is fairly well held in by the connectors and is not subject to cable pulling forces.

Connect a Hitachi display type SP14Q006 or compatible to JP10. The application board's corner mounting holes enable it to be mounted directly on pillars on the display module.

Other types of display can be connected via a suitable adapter to JP9, which will also work with the adapter supplied with the SP14Q006 starter kit.

The Hitachi touch screen can be connected to JP14.

Other electrically compatible touch screens can be adapted to connect to JP13.

Consult the pinout diagrams below for interconnection details.

JP10 – Flat Cable Display Connector

This FPC connector is compatible with the Hitachi SP14Q006 display.

1	LCDD4	Display data
2	LCDD5	Display data
3	LCDD6	Display data
4	LCDD7	Display data
5	LCDPWROFF	H=display off, L=display on
6	LCDFRAME	Frame clock
7		
8	LCDLINE	Line clock
9	LCDCLK	Dot clock
10	V _{CC}	+5V supply
11	GND	
12	V _{EE}	-21V ±1V (for Hitachi)
13	GND	
14	GND	

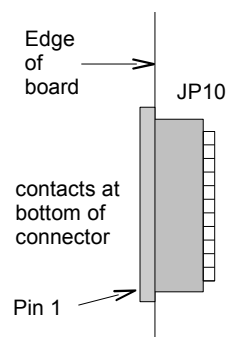

JP9 – Generic QVGA Display Connector

This is compatible with the connector adapter supplied with the Hitachi SP14Q006 display starter kit. It provides all the connections available from the QVGA display driver module, including touch screen connections, and is designed to be easily adapted to the requirements of most other QVGA display hardware via a suitable intermediate connector adapter. For more information on the signal usage see the QVGA (5809) data sheet.

0.1" pin header 2 x 14 pins

1	D1	LCDD5
2	D0	LCDD4
3	D3	LCDD7
4	D2	LCDD6
5	D5	
6	D4	
7	D7	
8	D6	
9	LCDPWROFF	H=display off, L=display on
10	GND	
11	LCDFRAME	Frame clock
12	LCDCLK	Dot clock
13	LCDLINE	Line clock
14	GPIO0	General purpose I/O
15	GND	
16	LCDPWRON	L=display off, H=display on
17	V _{EE}	Negative supply: set with R8 and LK1
18	V _{CC}	
19	GND	
20	V _{ADJ}	Contrast voltage: set with R7
21	VBATT2	
22	VBATT1	
23	IN2	Analogue inputs (see QVGA documentation)
24	IN1	
25	X-	
26	X+	Touch Screen Inputs (see QVGA documentation)
27	Y-	
28	Y+	

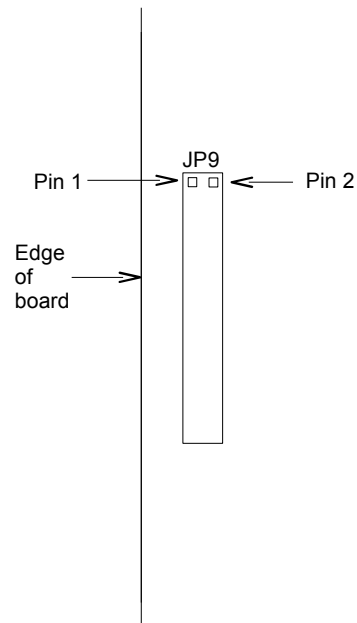

Note that Hitachi's own adaptor has pin 1 shown in the position of pin 2 and vice versa.

JP14 – Touch Screen 1

This 4-way FPC connector is compatible with the touch screen fitted to the Hitachi SP14Q006.

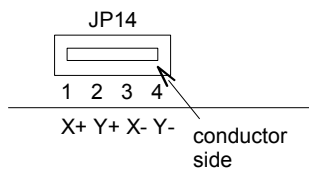

JP13 – Touch Screen 2

The same touch screen inputs are also provided on this 4 pin header.

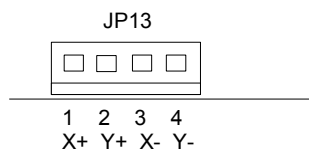

QVGA Configuration

```
MAKE lcdpower Digital(22)
lcdpower.On
MAKE display GraphicsLCD (3,320,240, $e)
```

The digital output on channel 22 controls the power supply to the DC-DC converter that provides the negative supply rail V_{EE} for the display LCD. Please consult the display manufacturer's instructions for the best sequence and timing for starting the controller and turning on the LCD power.

The value $\$e$ of the last parameter in the display MAKE statement selects the correct module when addressing the GLCD on the application board.

Touchscreen Configuration

```
MAKE t Touchscreen(0, 1, 144)
```

The second parameter selects I²C bus 1.

Display Supply and Contrast Voltage Adjustment

QVGA displays require a negative voltage supply. The voltage range required varies with the make of display, and the exact optimum voltage may vary from one unit to another as well as with temperature. Depending on the display specification the voltage may be referenced to ground or to the +5 volt rail. Additionally a contrast adjustment voltage is needed. Sometimes this is achieved by varying the supply voltage itself, otherwise by a separate control voltage supplied through another pin on the connector. The application board can provide a negative rail V_{EE} of 0 to -24 volts referenced to either ground or the +5V rail, adjustable and with a low source impedance from an emitter follower buffer. A contrast adjustment voltage derived from V_{EE} via a 10k pot R7 is also available.

R8 controls the V_{EE} voltage. Set this before adjusting R7.

LK1: link pins 1-2 for V_{EE} referenced to V_{CC} ; link 2-3 for V_{EE} referenced to GND. [Pin 1 is near TR2]

R7 sets the contrast adjustment voltage V_{ADJ} . Set V_{EE} with R8 before adjusting R7.

To avoid damage do not connect the display initially and follow this sequence:

1. Power on, turn on digital port 22 as described above. Set link LK1 and R8 for the correct voltage V_{EE} .
2. Power off.
3. Connect the display.
4. Power on and turn on digital port 22 as described above.
5. Re-adjust V_{EE} (R8) as it may have dropped slightly because of the current drain of the display.
6. If the display uses V_{ADJ} , adjust R7 for best contrast.

I²C Buses

There are two I²C buses available. They come out on JP7 & JP15 which are compatible with other Micro-Robotics products. They are also available on JP4.

I²C Bus 1

Connector: JP7

5 way 0.1" header

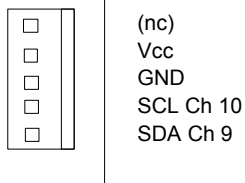

The following I²C addresses are assigned:

- 126 Keypad (digital channels 248-255)
- 144 Touch Screen (if QVGA module fitted)
- 160 Clock/Calendar (if fitted to Vm-1)
- 162 EEPROM on application board
- 164 EEPROM on ethernet module (if fitted)

I²C Bus 2

Connector: JP15

5 way 0.1" header

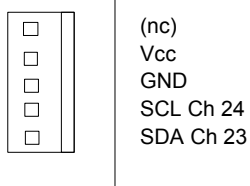

I²C Bus 2 is not used for any of the on-board functions of the application board: all addresses are available for external use.

Configuration

```
MAKE net I2Cbus      ; create bus 1
MAKE net I2Cbus(1)  ; create bus 1 (same as above)
MAKE net2 I2Cbus(2) ; create bus 2
```

Alphanumeric LCD Display Connector JP16

GND	D7	D5	nc	nc	E	RS	5V
15	13	11	9	7	5	3	1
16	14	12	10	8	6	4	2
5V	D6	D4	nc	nc	R/W	Cont.	GND

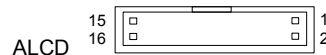

This boxed header is a reverse DIL connector allowing a transition connector to be used on the back of Hitachi and Hitachi-compatible alphanumeric LCD displays. The display connector is connected to the expansion bus, Location 0.

You cannot use the AlphaLCD at the same time as the QVGA module.

Configuration

```
MAKE lcd AlphaLCD(16, 2, 0) ; 16 char 2 line
MAKE lcd AlphaLCD(20, 4, 0) ; 20 char 4 line
```

Keypad/Digital I/O Connectors

A PCF8574A IC on I²C Bus 1 provides an eight bit data port. It can be used for digital I/O or a Keypad.

Pin	Channel
1	248
2	249
3	250
4	251
5	252
6	253
7	254
8	255

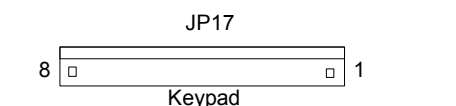

Configuration

```
MAKE kp Keypad (0, 248) ; 4x4 keypad
MAKE kp Keypad (1, 248) ; 8x8 keypad
```

EEPROM

The EEPROM is at address 162 on I²C Bus 1. It contains 256 bytes of non-volatile rewritable memory typically used by applications for storing configuration information.

Configuration

```
MAKE eeprom SafeData(0, 1, 162)
```

VM-1 Expansion Connector JP4

A pattern of pads suitable for a 0.1" double row header marked JP4 is provided for external connections to the VM-1 channels. The pin numbers on the connector have the same functions as those on JP2 on the VM1 – see the VM-1 data sheet for pin assignments and notes on channel use. All are available, with the following exceptions or limitations:

JP4 Pin	VM-1 Channel	Use	Notes
23	22	LCD Power	Used to control the power to the DC-DC converter that supplies V_{EE} . You can use channel 22 for other purposes if you aren't using the QVGA bias voltage cct; if you don't want the bias power circuit switched by Ch 22 then you should remove R6 and pull up the gate of TR1 to Vcc.
24	8	WAIT/	Used by QVGA module: do not use for any other pupose if you are using QVGA
26,28	9, 10	I ² C Bus 1	Note I ² C bus 1 is used on board and also available on JP7
30,32,34,36	11, 12, 13, 14	Serial port 1	Normally used for terminal access via JP5. If you really want to use serial port 1 at logic levels or use these channels for general digital I/O, remove IC U3 from its socket.
29,31,33,35	25, 26, 27, 28	Serial port 2	If you wish to use serial port 2 at logic levels instead of RS-232 voltages, or use these channels for general digital I/O, remove IC U4 from its socket.

Power Supply

The 5811 may be powered from a supply voltage range of 7 to 30 volts unregulated DC. The current consumption depends on the modules fitted and other devices attached, and how hard the VM-1 processor is working. There is also a regulated 5V output for powering external circuits.

Drawing a high current or using a high input supply voltage will cause high dissipation in the regulator heatsink. We have tested the combination of ethernet, QVGA and display including backlight all running from onboard 5V regulator with an incoming supply of 8V. No damage was sustained but the heatsink becomes very hot and we would not recommend using it this way in production systems. Use a bigger heatsink and/or separate power supply for external components such as the backlight. The heatsink and regulator are positioned so that they can be attached to an external heatsink or casing if necessary. Note that the regulator tab and heatsink are connected to ground.

The application board will draw typically 100 – 150mA by itself.

The ethernet card draws approximately 55mA extra when fitted.

The QVGA display control module draws approximately 40mA extra when fitted.

The LCD display unit itself also draws current from both the 5V and V_{EE} supplies, the latter derived from 5V.

Pinout

Connector JP3 – Plug Provided

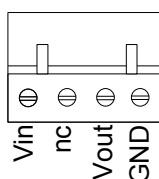

4-way pluggable screw terminal

Schematics

Main VM-1 and Module interface, Power

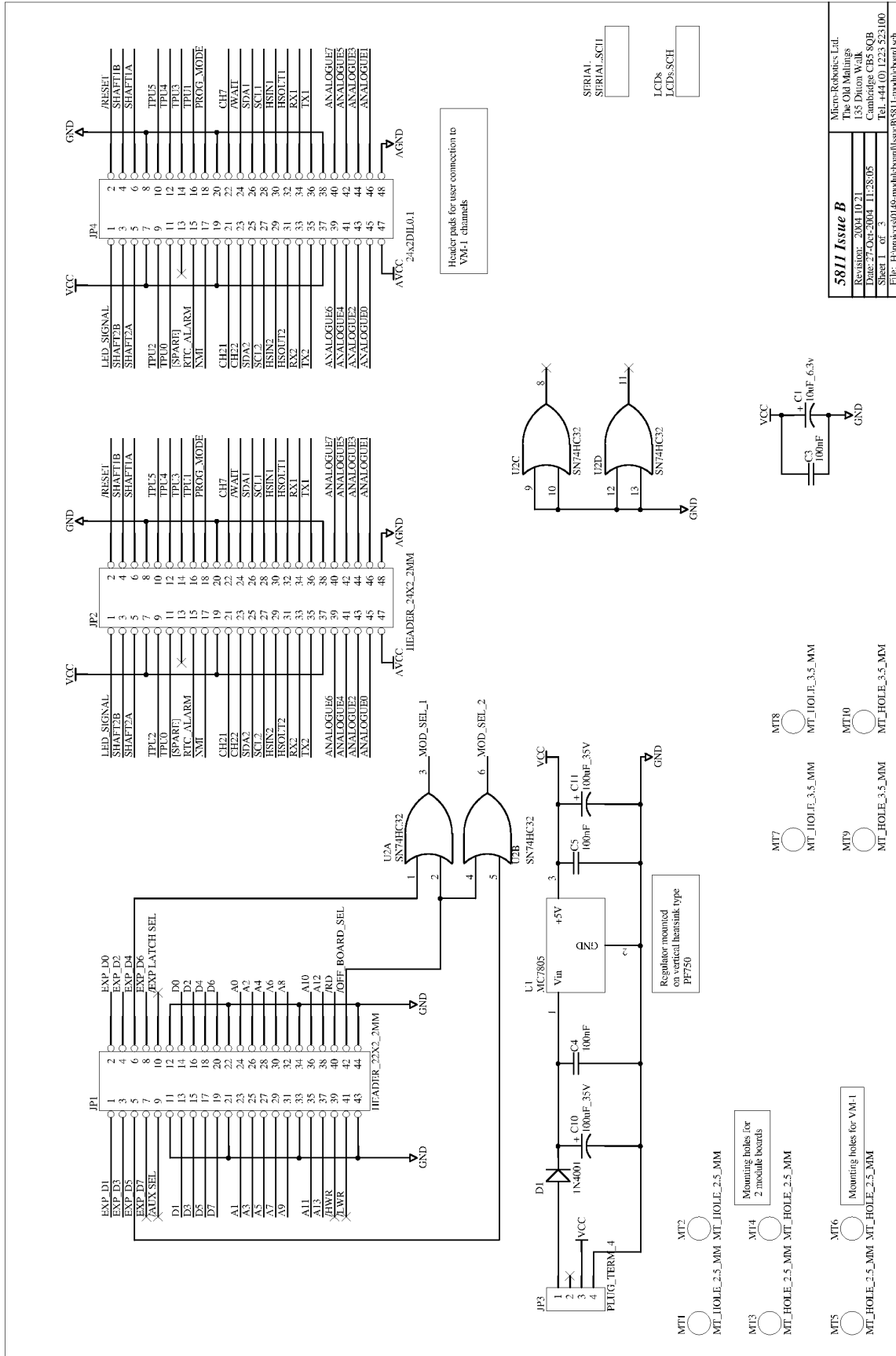

5811 Issue B	
Revision:	3/04 10/31
Date:	27/03/2004 11:28:05
Sheet 1 of 3	
Micro Robotics Ltd. 138 Dunstable Rd. Cambridge CB5 5QB Tel: +44 (0) 1223 523100 File: Hyprkcs0109-mainboardIssueB5811-mainboard.sch	

Serial Schematic

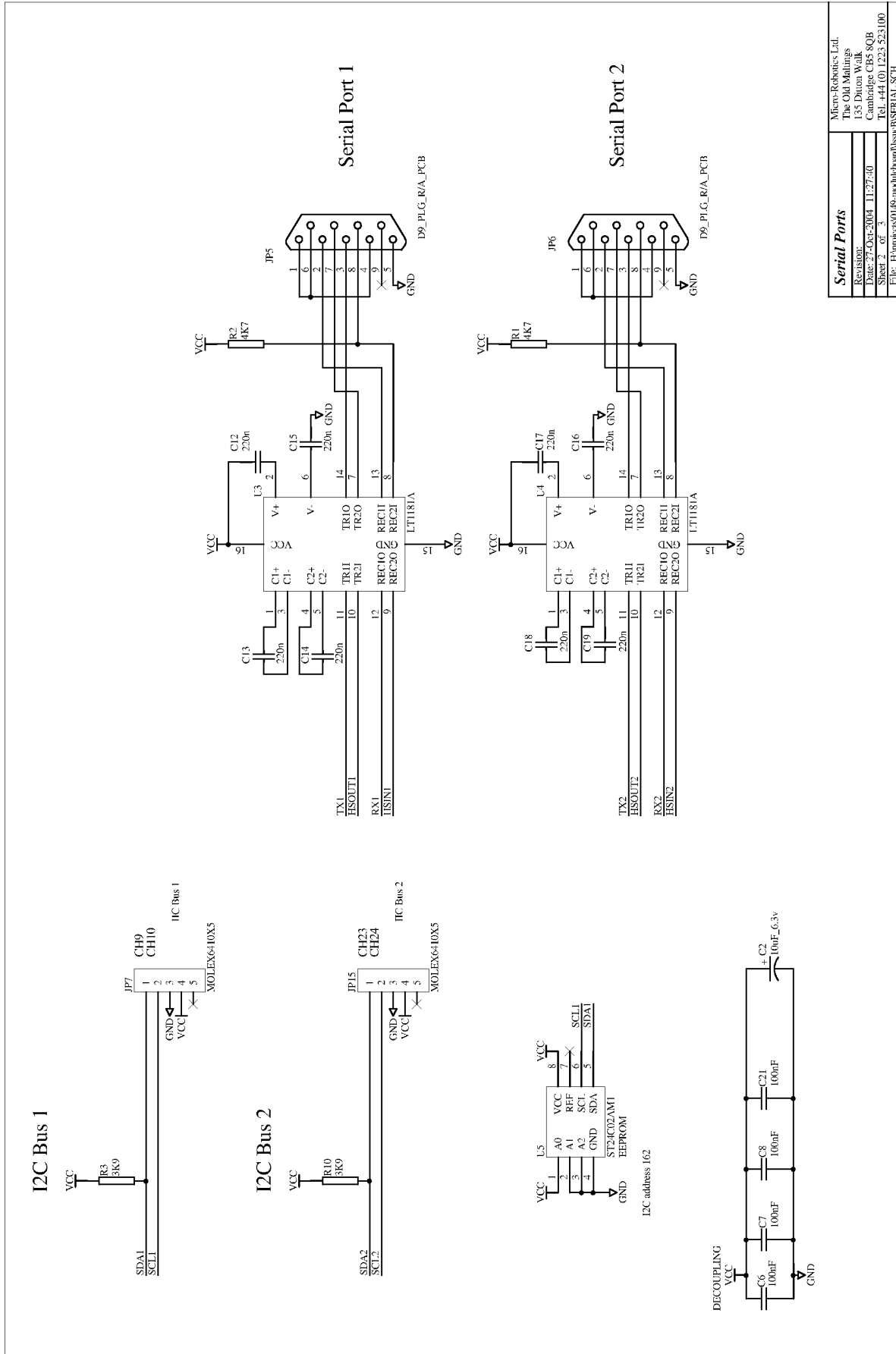

Serial Ports	
Revision:	1.35
Date:	27-Oct-2004 11:27:40
Sheet 2 of 3	
File:	H:\projects\0119-machibon\board\boards\SERIAL.SCH

LCD connection schematic

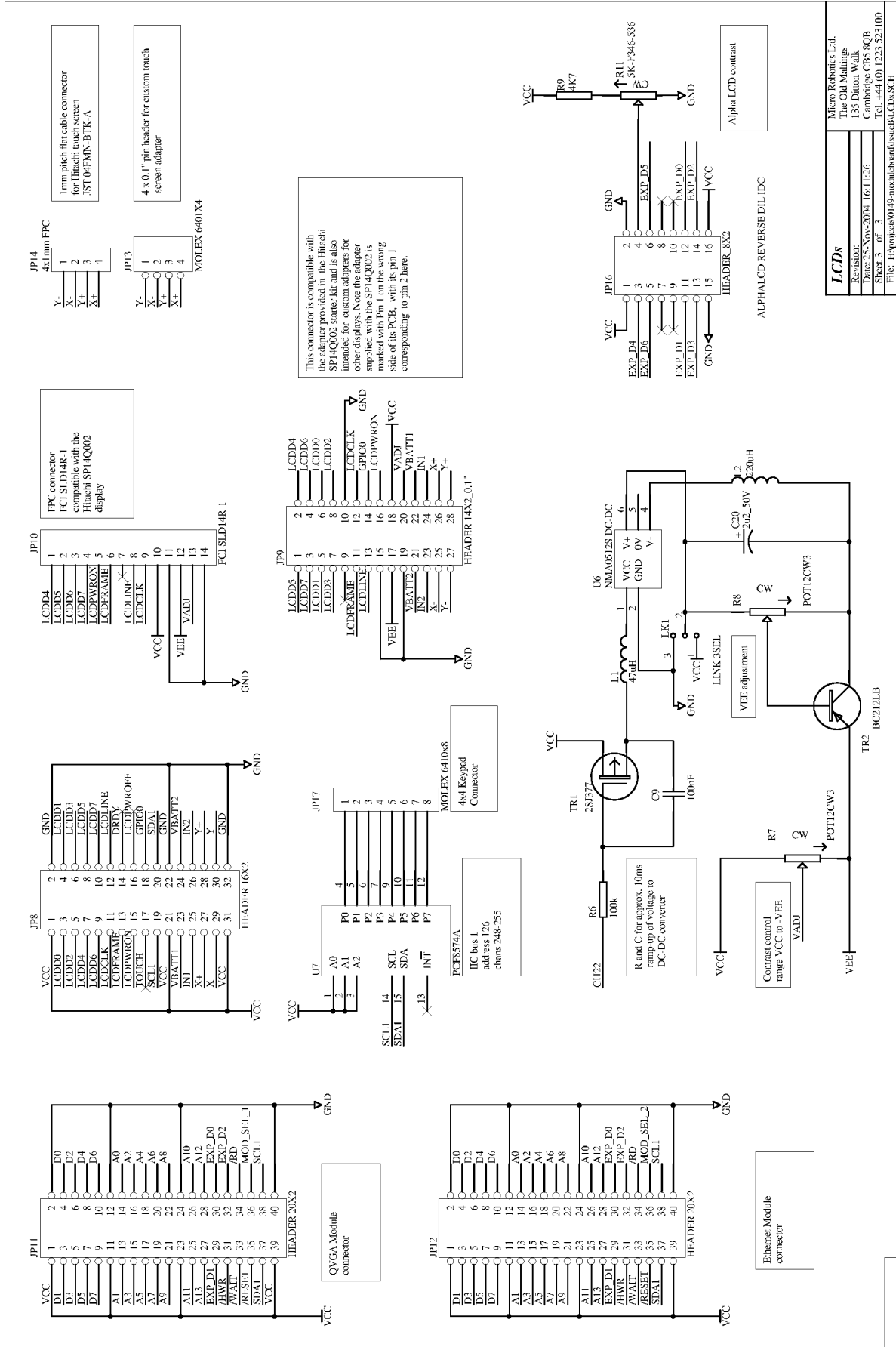

LCDs	
Micro-Robotics Ltd.	
The Old Millings	
135 Dutton Walk	
Cambridge CB5 9QB	
Sheet 3 of 5	
File: H:\projects\0119-mux\lib\board\lcd\lcd_sch	